



Congratulations! You have purchased one of many Pragmatic's finest products! We guarantee that you will be satisfied with the purchase, and if you need further technical assistance, please feel free to contact one of Pragmatic Engineers at 408-735-0300

INSTRUCTION FOR USING TPA

Each TPA pairs has both the sender and receiver.

To use : Attach your line level audio out (RCA Cable) to the RCA Input on either of the TPA units. Connect the sending unit and the receiving unit with a CAT5 cable. This cable can be run as far as 1000 feet. On the receiving end, connect the TPA unit to your line level in of your amplifier/pre-amplifier.

If you like, you can daisy-chain up to 16 TPA receiver(connect the receiver one after another to the main line.)

PRAGMATIC COMMUNICATIONS SYSTEMS INC.

2340A Walsh Avenue, Santa Clara, CA. 95051

Tel. 408 748 1100 Fax 408 663 9783

website: <http://www.wireless-experts.com>

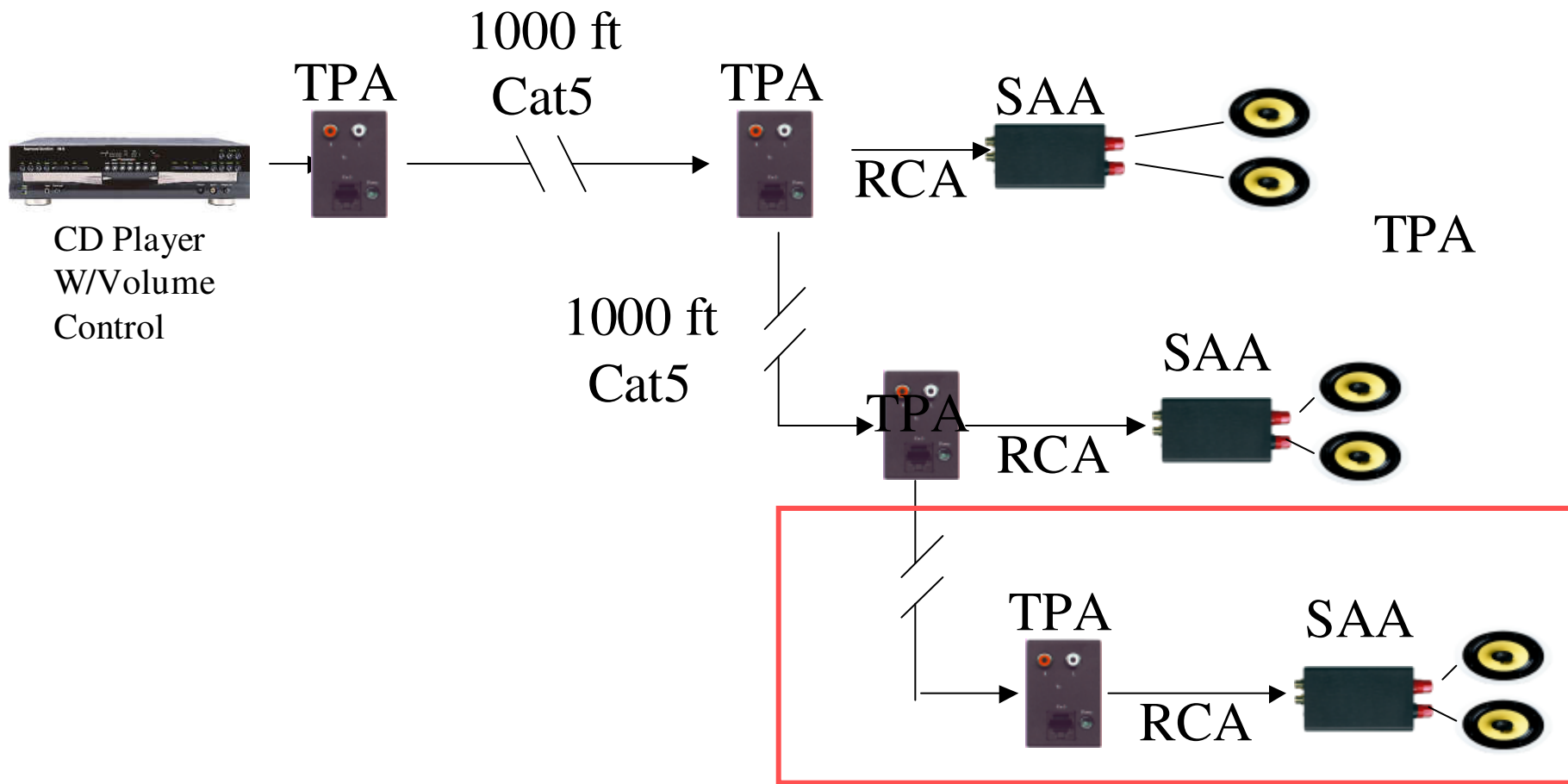

pragmatic